

SECTION 8.1

Ancillaries - Specification

October 2024

IKO ELITE RAINWATER OUTLETS

PRODUCT INFORMATION

All rainwater outlet components are manufactured from marine grade aluminium to give an extensive life expectancy of at least 50 years.

To ensure ultimate reliability and confidence, the elite rainwater outlet range has been rigorously tested to withstand water depths surpassing 1m.

The elite range incorporates PVCu pipe connectors, providing an air tight seal and thermal break between the outlet body and connecting pipework, preventing cold bridging.

Our range of outlets connects to all common PVCu, HDPE and socketless cast iron pipework sizes.

Supplied threaded PVCu pipe connectors are manufactured from BS EN 1329 pipework and are therefore suitable for use with pipe wraps and fire collars.

Aluminium is a sustainable material, infinitely recyclable and responsibly sourced.

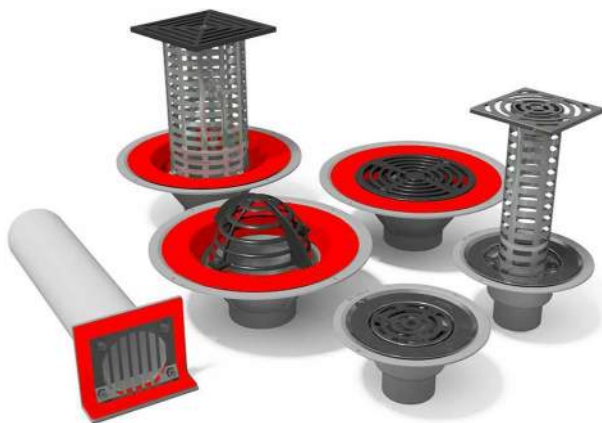

USE

Rainwater outlets for use within new build and refurbishment flat roofing and balcony and terrace applications. Elite rainwater outlets, together with ancillary components are suitable for use with IKO Reinforced Bitumen Membrane Systems, IKO Permasec hot melt system, and IKO flexia liquid applied systems.

These products must be installed by an IKO Approved or Registered Installer. All work must be undertaken in accordance with the requirements of the specific information provided with the issued IKO Specification document, or guidance documents where applicable.

MAINTENANCE

For optimum performance rainwater outlets should be inspected and cleared every six months to ensure peak operation.

FEATURES & BENEFITS

Compliant - Drainage flow performance to BS EN 12056

High Flow Performance - Deep integral sump for controlled flow of water into pipe.

Domical Grates - Prevent water swirl and air entrapment enabling the outlet to drain at optimum pipe capacity.

Marine Grade Aluminium - Robust, economical material.

Robust Detailing - Clamping ring secures membrane ensuring total integrity of seal.

Low Maintenance - Domed grates on outlets permit a free flow of rainwater while preventing loose chippings or debris from entering the outlet.

Developed Range - Covers most types of flat roof drainage applications, with extension pieces, pipe adaptors and grates including flat grates available for trafficked and terraced areas.

PERFORMANCE & COMPOSITION

General Data*

Composition:	Metal
Form:	Solid cast
Colour:	Aluminium

* For specific unit data and Product Codes, please refer to rear pages of this document

DIRECTIONS FOR USE

MATERIAL HANDLING

Checking: Outlets should be checked to ensure that they conform to the project specification.

Handling: Outlets should be unloaded and handled with care to avoid damage.

Site Storage: Outlets should be stored in their original packaging, in an area where they will not become damaged.

PRIOR TO COMMENCEMENT

Any roofing works, inclusive of new installations as part of a new roofing system or refurbishment work at outlet positions on existing roofs must always follow good, safe working practice.

Prior to commencing works, it is advisable to consult Health and Safety Executive Guidance documents such as HSG33 'Health and Safety in Roof Work', irrespective of levels of competence, to ensure all works are being planned and undertaken in a safe, pragmatic manner.

Roof components and enabling works, should only be undertaken by those competent, conversant and capable of completing roofing works.

SURFACE PREPARATION

Please refer to relevant pages of this document for specific information on specified unit.

APPLICATION

Please refer to relevant pages of this document for specific information on specified unit.

RAINWATER DESIGN

Rainwater Outlets should be installed at the lowest points of the roof. The size and number of outlets required should be determined by rainwater calculations in accordance with BS EN 12056-2:2000 - *Gravity drainage systems inside buildings. Sanitary pipework, layout and calculation.*

Contact IKO Technical for further guidance.

DISCLAIMER

Whilst every precaution is taken to ensure that the information given in this literature is correct and up to date it is not intended to form part of any contract or give rise to any collateral liability, which is hereby specifically excluded.

IKO reserve the right to amend and/or withdraw this document without notice. Intending purchasers of our materials should therefore verify with the company whether any changes in our specification, application details, withdrawals or otherwise have taken place since this literature was issued.

OUTLET PRODUCT INFORMATION

IKO ELITE DOME GRATE OUTLET

Use: Primarily suited for use with warm roofs and cold/ uninsulated roof build ups.

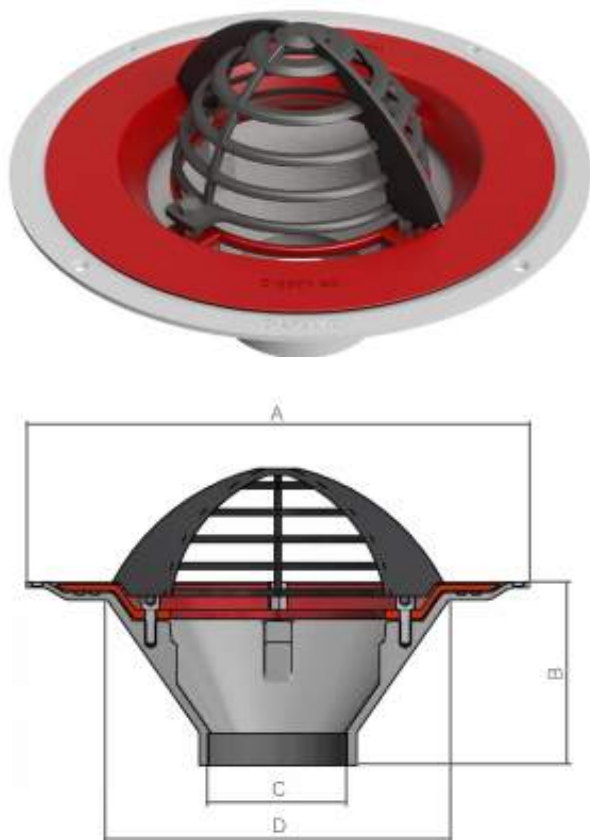

System components

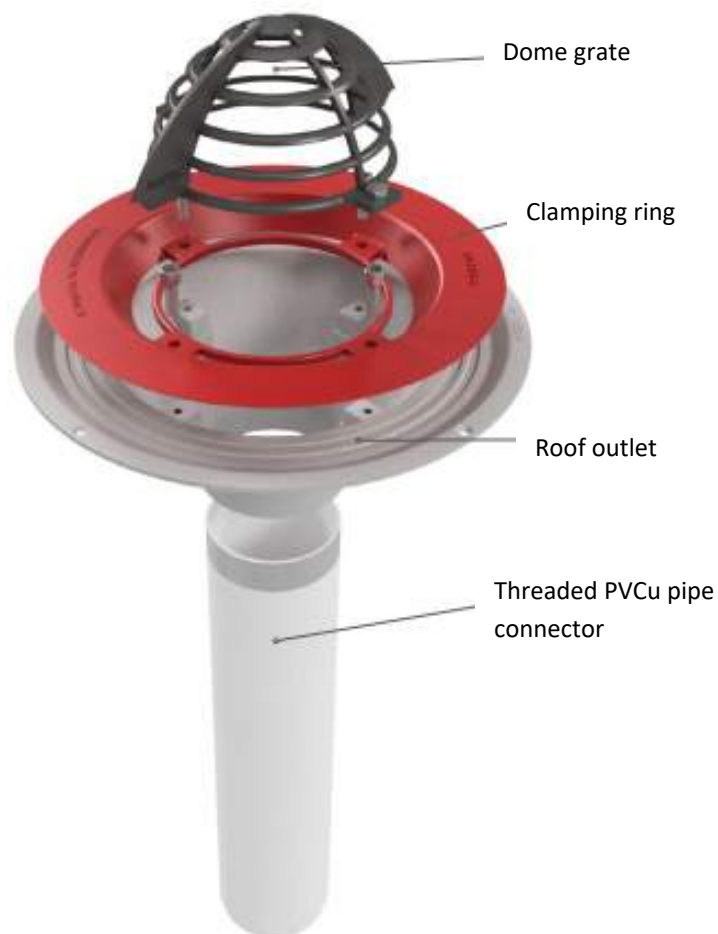

IKO Code	581D0082	581D0110	581D0160
Reference	IKOAR82D	IKOAR110D	IKOAR160D
Pipe connection size (OD)	Ø82mm	Ø110mm	Ø160mm
A (mm)	377	377	377
B (mm)	111	136	111
C (mm)	82	110	160
D (mm)	255	255	255
Max flow rate (l/s)*	5	10.7	19

*Seal threads with silicone sealant.

* Flow rates are measured at 35mm head of water for outlets up to Ø110mm and 45mm head of water for Ø160mm, in accordance with BS EN 1253-2.

Units are supplied with 500mm long threaded PVCu pipe connectors.

IKO ELITE FLAT GRATE ROOF OUTLET

Use: Primarily suited for use with warm roofs, terraces, walkways and cold/ un-insulated roof build ups.

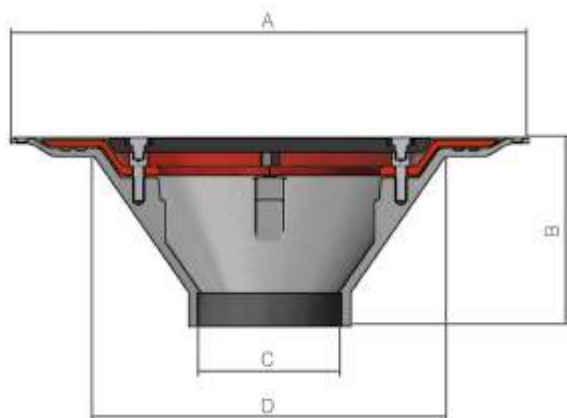

System Components

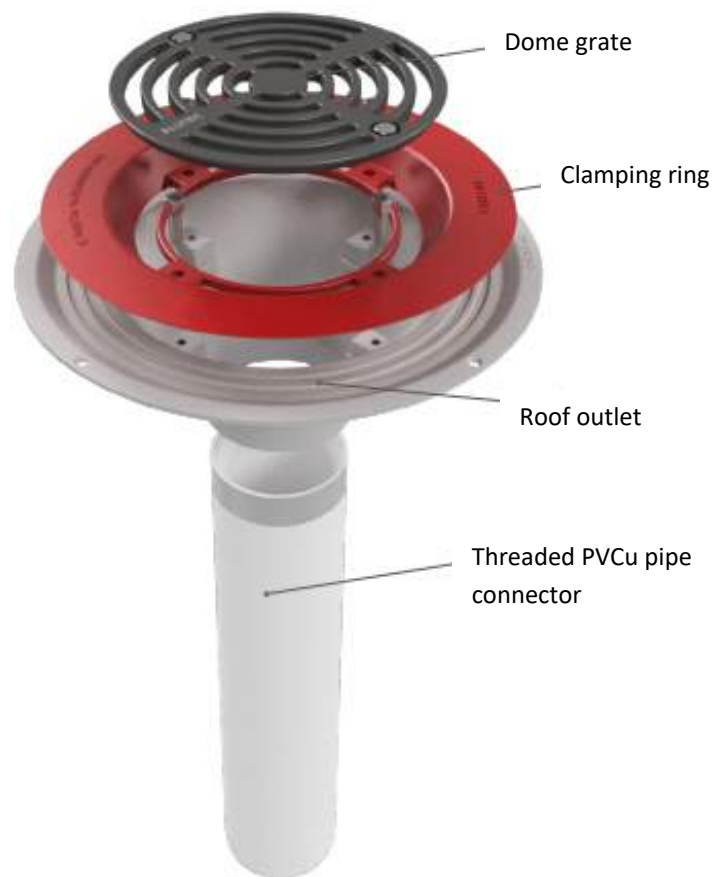

IKO Code	581F0082	581F0110	581F0160
Reference	IKOAR82F	IKOAR110F	IKOAR160F
Pipe connection size (OD)	Ø82mm	Ø110mm	Ø160mm
A (mm)	377	377	377
B (mm)	111	136	111
C (mm)	82	110	160
D (mm)	255	255	255
Max flow rate (l/s)*	5	10.7	19

* Flow rates are measured at 35mm head of water for outlets up to Ø110mm and 45mm head of water for Ø160mm, in accordance with BS EN 1253-2.

Units are supplied with 500mm long threaded PVCu pipe connectors.

*Seal threads with silicone sealant.

IKO ELITE CAR PARK OUTLET

Use: Primarily suited for use within car parks applications.

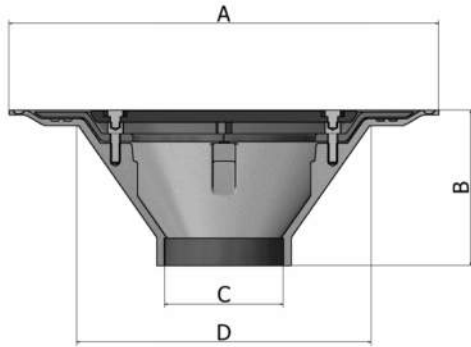

IKO Code	581CP082	581CP110	581CP160
Reference	IKOAC82	IKOAC110	IKOAC160
Pipe connection size (OD)	Ø82mm	Ø110mm	Ø160mm
A (mm)	377	377	377
B (mm)	111	136	111
C (mm)	82	110	160
D (mm)	255	255	255
Max flow rate (l/s)	5	10.7	19

Load rating 1.5tonnes, class K

IKO ELITE FLAT GRATE BALCONY OUTLET

Use: Primarily suited for use with uninsulated balconies/ walkways and terraces.

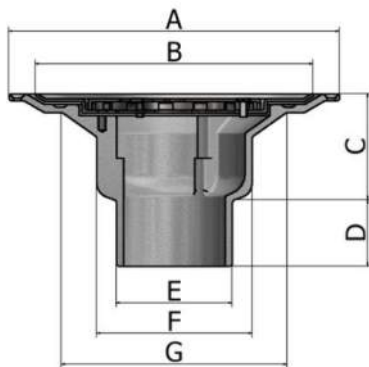

IKO Code	581B0000
Reference	IKOAB01
Pipe connection size (OD)	Ø76, 72x72, Ø82 and Ø110mm
A (mm)	234
B (mm)	196
C (mm)	77
D (mm)	45
E (mm)	82
F (mm)	110
G (mm)	158
Max flow rate (l/s)*	4.7

* Flow rate measured at 35mm head of water

IKO ELITE TERRACE GRATE BALCONY OUTLET

Use: Primarily suited for use with inverted podiums, decking and paved balconies, and walkways.

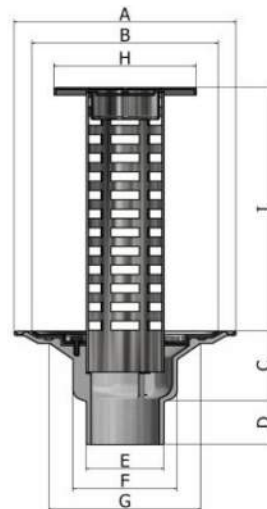

IKO Code	581BT000
Reference	IKOAB01TG
Pipe connection size (OD)	Ø76, 72x72, Ø82mm and Ø110mm
A (mm)	234
B (mm)	196
C (mm)	77
D (mm)	45
E (mm)	82
F (mm)	110
G (mm)	158
H (mm)	150
I* (mm)	260
Max flow rate (l/s)**	4.7

* Cut down to suit requirement

** Flow rates are measured at 35mm head of water

Connection to aluminium pipework

Each balcony outlet is supplied with an EDPM rubber adaptor that allows direct connection to Ø76mm and 72x72mm aluminium pipework

IKO ELITE BALCONY OUTLET

Use: Primarily suited for use with uninsulated balconies/ walkways and terraces.

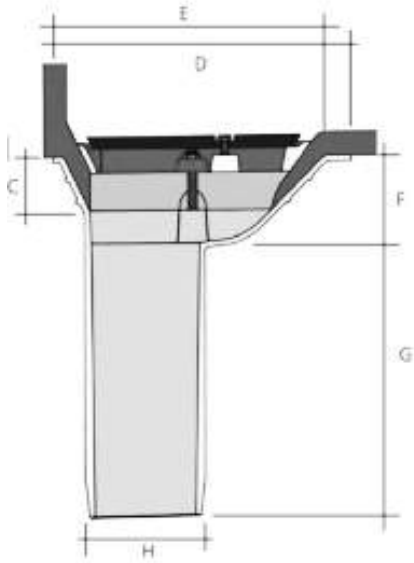

IKO Code	IKODR360	IKODR460
Reference		
Pipe connection size (OD)	75	100
A (mm)	230	230
B (mm)	190	190
C (mm)	50	50
D (mm)	265	265
E (mm)	240	240
F (mm)	85	85
G (mm)	260	260
H (mm)	83	110
Max flow rate (l/s)**	5	7.55

IKO ELITE TWO WAY PARAPET OUTLET

Use: Primarily suited for use with parapet wall penetration and internal gutters. Outlet can be set horizontal or vertical. These outlets are suitable for IKO Reinforced Bitumen Membranes and IKO flexia liquid applied systems.

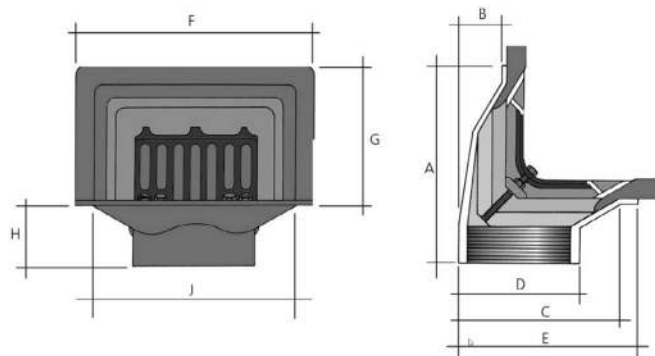

IKO Code	Various
Reference	N/A
Pipe connection size (OD)	Ø110mm
A (mm)	213
B (mm)	50
C (mm)	170
D (mm)	130
E (mm)	193
F (mm)	255
G (mm)	148
H (mm)	70
J (mm)	217
Max flow rate (l/s)* - horizontal	2.38
Max flow rate (l/s)* - vertical	7.83

* Flow rate measured at 35mm head of water, performance will dramatically increase if outlets are sumped. E.g. 100mm sump = 9.8 l/s.

Units are supplied with 500mm long threaded PVCu pipe connectors.

IKO PREFORMED PARAPET CHUTE

Use: There are two sizes available: IKOPC300 and IKOPC500. These are suitable for IKO Reinforced Bitumen Membranes; IKO flexia liquid applied waterproofing and IKO Permateg hot melt systems. Aluminium leaf guard gratings are also provided where required.

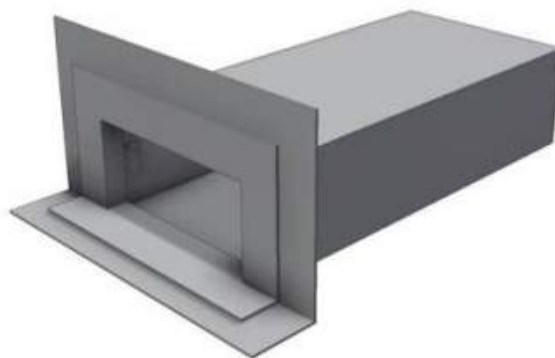

IKO Code	581PC300	581PC500
Reference	IKOPC300	IKOPC500
Description	Parapet chute 300mm	Parapet chute 500mm
Size (mm)	300(w) x 600(d) x 150(h)	500(w) x 600(d) x 150(h)
Performance flow rate (l/s)*	7.32	12.2

* Flow performance is based on a 35mm head of water. If outlets are located within localised sumps, greater performance will be achieved.

IKO ELITE EXTENDED GRATE ROOF OUTLET

Use: Primarily suited for use with inverted roofs, green roofs, terraces, podiums, walkways and paved areas.

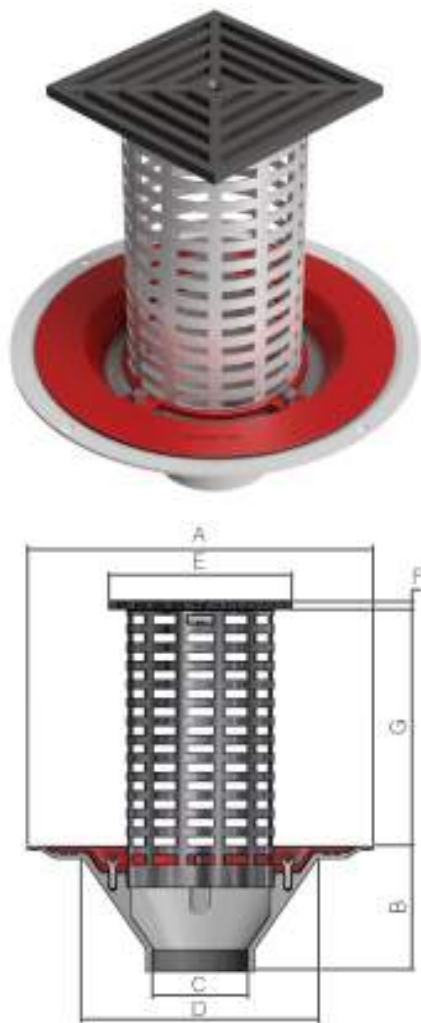

System Components

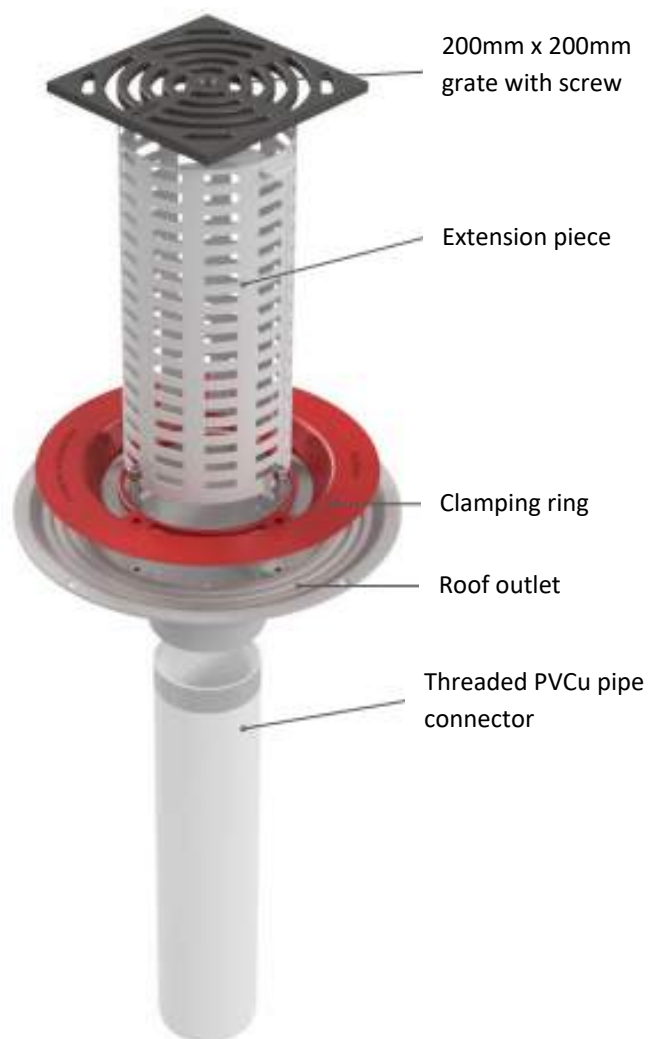

*Seal threads with silicone sealant.

IKO Code	58100082	58100110	58100160
Reference	IKOAR82TG	IKOAR110TG	IKOAR160TG
Pipe connection size (OD)	Ø82mm	Ø110mm	Ø160mm
A (mm)	377	377	377
B (mm)	111	136	111
C (mm)	82	110	160
D (mm)	255	255	255
E (mm)	200	200	200
F (mm)	10	10	10
Max flow rate (l/s)*	5	10.7	19

* Flow rates are measured at 35mm head of water for outlets up to Ø110mm and 45mm head of water for Ø160mm, in accordance with BS EN 1253-2.

Units are supplied with 500mm long threaded PVCu pipe connectors.

INSTALLATION

PARAPET OUTLET – WARM, COLD, & INVERTED ROOFS

1. Remove the L shaped membrane clamping flange and stainless steel grate, wax paper ring from butyl seal ring including three foam spacers located within the throat of the rainwater outlet and discard.
2. Insert the rainwater outlet with pipe adaptor fitted, into the opening and secure with 2 No A2 grade stainless steel screws (not provided) into the vertical background.
3. a) **IKO Reinforced Bitumen Membranes:** Create a 500mm square skirting from the waterproofing membrane and cut a 90mm x 112mm rectangular hole in the middle and place over the outlet body and butyl strips.
b) **IKO flexia** liquid systems: Dress the waterproofing membrane over the recessed grooves of the outlet body.
4. Place L shaped membrane clamping flange and grate over the waterproofing membrane, then secure to outlet body with 4No male insert bolts. Tighten bolts in a diagonal sequence to ensure even compression. Check tightness after 15-30mins and further tighten if required.

For inverted roofs a localised sump adjacent to the outlet should be left within the insulation of approximate 200mm x 200mm in size. The void area can be left open or back filled with ballast.

PARAPET OUTLET – PREFORMED CHUTE OUTLETS

Parapet outlets consist of a body assembly, clamping ring and optional grate.

Prior to the installation of the full **IKO Permateg** hot melt System, Permaflash-D150 should be bonded in hot **IKO Permateg** to the surrounding substrate and onto the flange of the outlet.

The waterproofing should be dressed into the body of the outlet; clamping ring is then secured over the waterproofing layer with retaining screws provided, to prevent water ingress between waterproofing membrane and parapet outlet. The optional grate acts as a guard against airborne debris from blocking the outlet.

COLD ROOFS & CAR PARKS

1. Remove the dome/grade membrane clamping ring. Remove the wax paper ring from the butyl seal rings including three foam spacers located within the throat of the rainwater outlet, and discard as waste.
2. Insert rainwater outlet with pipe connector fitted centrally into the structural opening.
3. a) **IKO Reinforced Bitumen membranes:** Cut a 500mm square piece of the waterproofing membrane with a 220mm diameter hole in the centre and place centrally over the rainwater outlet. Prime.
b) **IKO flexia** liquids systems: Dress/apply waterproofing membrane over the recessed grooves of the outlet body.
b) Prior to the installation of the full **IKO Permateg** System, Permaflash-D500 should be bonded in hot **IKO Permateg** to the surrounding substrate and into the flange of the outlet.
4. Place membrane clamping ring over the waterproofing membrane, then secure to outlet body with 4No bolts insert bolts. Tighten bolts in a diagonal sequence to ensure even compression. Check tightness after 15-30mins and further tighten if required.
5. Attach grating.

WARM ROOFS

IKO Reinforced Bitumen Membranes and **flexia** liquid:

1. The Air and Vapour Control Layer must be cut and sealed around the downpipe opening.
2. Create a 340mm x 340mm internal dimension timber or other suitable material kerb around the rainwater outlet structural opening to the same height as the insulation.
3. Flashing pieces of the Air and Vapour Control Layer should be dressed over the kerb and sealed to the main Air and Vapour Control Layer.
4. Place rainwater outlet onto the raised kerb, mark and recess the four contact areas so the top of the rainwater outlet and insulation are at the same height. Then secure with 4No A2 stainless steel screws (not supplied).

5. Cut rigid sections of insulation to infill the corners of the timber kerb.
6. Cut a 500mm square piece of waterproofing membrane with a 220mm diameter hole centrally.
7. Remove the dome/grade membrane clamping ring. Remove the wax paper ring from the butyl seal rings including three foam spacers located within the throat of the rainwater outlet, and discard as waste.
8. Apply the 500mm square piece of the waterproofing membrane with a 220mm diameter hole in the centre and place centrally over the rainwater outlet.
9. Prime.
10. Place membrane clamping ring over the waterproofing membrane, then secure to outlet body with 4 No bolts insert bolts. Tighten bolts in a diagonal sequence to ensure even compression. Check tightness after 15-30mins and further tighten if required.
11. **IKO flexia** liquid systems only: dress/apply waterproofing membrane over the recessed grooves of the outlet body.
12. Attach grating.
4. Place membrane clamping ring over the waterproofing, then secure to outlet body with 4 No male/female insert bolts. Tighten bolts in a diagonal sequence to ensure even compression. Check tightness after 15-30mins and further tighten if required.
5. Insert the 160mmØ perforated extension into the outlet throat. Place PIR insulation around the perforated extension. Cut 160mmØ perforated extension to the required height (level with the finished top layer).
6. Remove perforated extension ring and dress the water run off layer (WFRL) into the insulation void, then reinsert the perforated extension ring.
7. Insert the grate retaining bar through the uppermost perforations so that the threaded fixing hole is central. Place the square grating into position and secure with screw provided.
8. Apply any further roof build up components and dress around the outlet extension ring.

UNINSULATED BALCONIES

1. Remove the membrane clamping ring. Remove the wax paper ring from the butyl seal rings including three foam spacers located within the throat of the rainwater outlet, and discard as waste.
2. Insert balcony outlet into the structural opening and secure with A2 grade stainless steel screws (not supplied).
3. a) **IKO Reinforced Bitumen Membranes:** Cut a 500mm square piece of the waterproofing membrane with a 135mm diameter hole in the centre and place centrally over the rainwater outlet. Prime.
b) **IKO flexia** liquids systems: Dress/apply waterproofing membrane over the recessed grooves of the outlet body.
b) Prior to the installation of the full **IKO Permateg** System, Permaflash-D500 should be bonded in hot **IKO Permateg** to the surrounding substrate and into the flange of the outlet.

INVERTED PAVED & GREEN ROOFS

1. Remove the membrane clamping ring. Remove the wax paper ring from the butyl seal rings including three foam spacers located within the throat of the rainwater outlet, and discard as waste.
2. Place rainwater outlet body with pipe connector fitted centrally over the opening.
3. a) **IKO Reinforced Bitumen Membranes:** Cut a 500mm square piece of the waterproofing membrane with a 220mm diameter hole in the centre and place centrally over the rainwater outlet. Prime.
b) **IKO flexia** liquid systems: Dress/apply waterproofing membrane over the recessed grooves of the outlet body.
b) Prior to the installation of the full **IKO Permateg** System, Permaflash-D500 should be bonded in hot **IKO Permateg** to the surrounding substrate and into the flange of the outlet.

4. Place membrane clamping ring over the waterproofing membrane, then secure to outlet body with 3No bolts provided. Tighten bolts in a diagonal sequence to ensure even compression. Check tightness after 15-30mins and further tighten if required.
5. Place circular grate over outlet and secure with screws provided.

PAVED/ DECKED BALCONIES

1. Remove the membrane clamping ring. Remove the wax paper ring from the butyl seal rings including three foam spacers located within the throat of the rainwater outlet, and discard as waste.
2. Insert balcony outlet into the structural opening and secure with A2 grade stainless steel screws (not supplied).
3. a) **IKO Reinforced Bitumen Membranes:** Cut a 500mm square piece of the waterproofing membrane with a 135mm diameter hole in the centre and place centrally over the rainwater outlet. Prime.
b) **IKO flexia** Liquids systems: Dress/apply waterproofing membrane over the recessed grooves of the outlet body.
b) Prior to the installation of the full **IKO Permateg** System, Permaflash-D500 should be bonded in hot **IKO Permateg** to the surrounding substrate and into the flange of the outlet.
4. Place membrane clamping ring over the waterproofing membrane, then secure to outlet body with 3No bolts provided. Tighten bolts in a diagonal sequence to ensure even compression. Check tightness after 15-30mins and further tighten if required.
5. Insert perforated extension into the outlet throat then mark the required height and cut down accordingly (5mm below finished floor level).
6. Press square tile grate spigot into the perforated extension.

INVERTED PODIUM/ BALCONIES

1. Remove the membrane clamping ring. Remove the wax paper ring from the butyl seal rings including three foam spacers located within the throat of the rainwater outlet, and discard as waste.

2. Insert balcony outlet into the structural opening and secure with A2 grade stainless steel screws (not supplied).
3. a) **IKO Reinforced Bitumen Membranes:** Cut a 500mm square piece of the waterproofing membrane with a 135mm diameter hole in the centre and place centrally over the rainwater outlet. Prime.
b) **IKO flexia** liquids systems: Dress/apply waterproofing membrane over the recessed grooves of the outlet body.
b) Prior to the installation of the full **IKO Permateg** System, Permaflash-D500 should be bonded in hot **IKO Permateg** to the surrounding substrate and into the flange of the outlet.
4. Place membrane clamping ring over the waterproofing membrane, then secure to outlet body with 3No bolts provided. Tighten bolts in a diagonal sequence to ensure even compression. Check tightness after 15-30mins and further tighten if required.
5. Insert perforated extension into the outlet throat then mark the required height and cut down accordingly (5mm below finished floor level). Place PIR insulation around the perforated extension.
6. Press square tile grate spigot into the perforated extension.

IMPORTANT

Common installation tasks applicable to all installations:

1. Fit threaded pipe connector into the outlet body as per label attachment to each threaded pipe connector, using silicone sealant (SC101)
2. Fit any structural voids to the underside of the outlet with mortar or insulation as appropriate.
3. Fit a fire collar or wrap around the protruding plastic pipe against the underside of the roof structure, if the pipe projects into the building.